

BottleSys G

Technology For The Fluid
Integrated Fluid Handling Glass Solution



If your application requires mixing of several base liquids to get your unique process fluid, you may be interested in integrated glass system.

- ✓Chemical compatibility
- ✓Process visibility through glass bottle
- ✓Customised level measurement
- ✓All-In-One solution
- ✓Volume for your process



„...Designed to make your life easier...”



SPECIFIC

Designed for you

IDEATION



MEASURABLE

Impacts your business

DESIGNING



ACHIEVABLE

From idea to success

PROTOTYPING



RELEVANT

Serves your application

TESTING



TIME-BOUND

Built on time

MANUFACTURING



OEMSYS Sp. z o.o.
Fabryczna 1
34-600 Limanowa
Poland

Technical specification	
Operating temperature	0..60°C
Fluid volume	4,5L
Bottle material	Glass
Wetted parts	PVC-U, PVDF

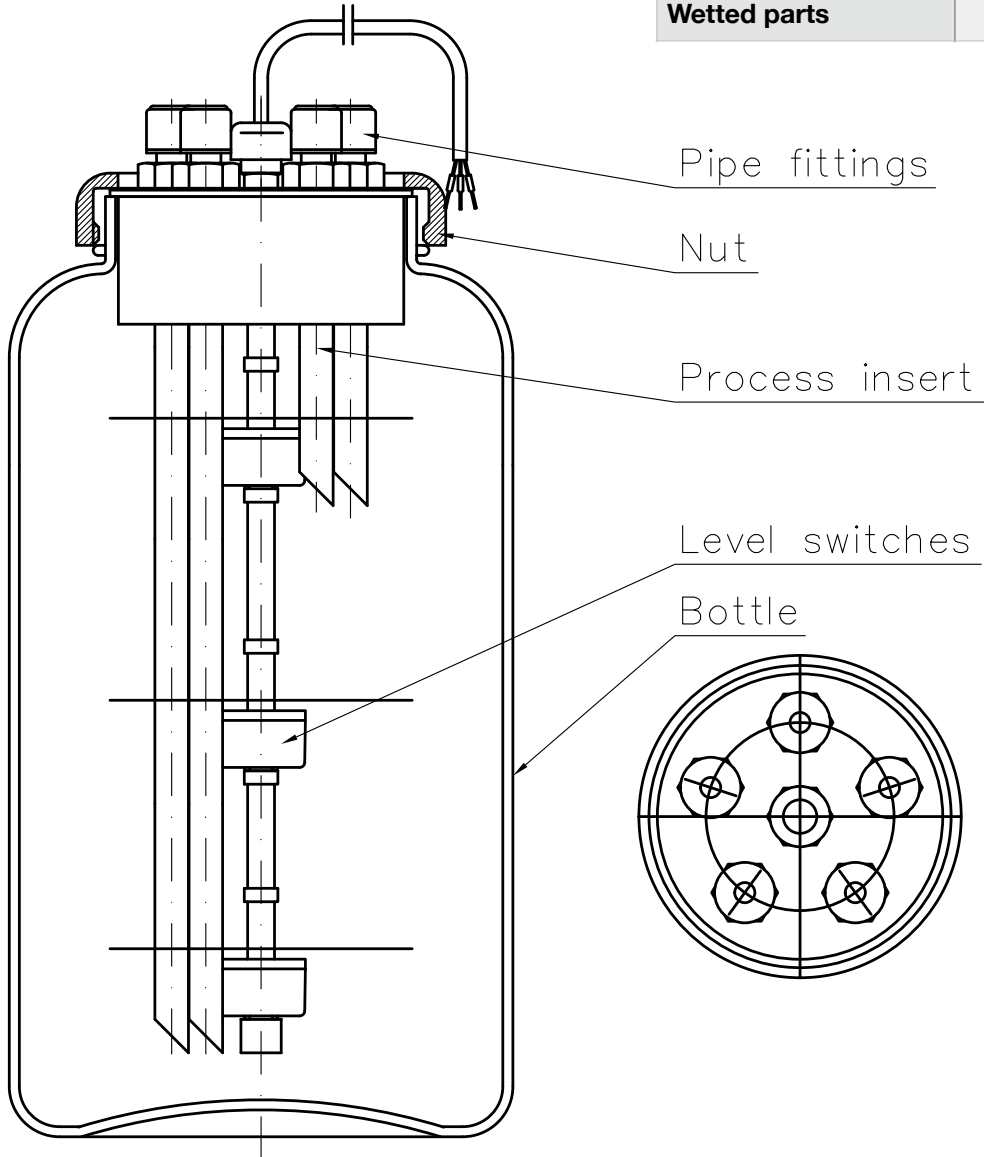

BottleSys G - **Cable length** - **Alarm 1** - **Alarm 2** - **Alarm 3**

[mm]	[mm] O-NO C-NC	[mm] O-NO C-NC	[mm] O-NO C-NC
------	----------------------	----------------------	----------------------

Consult factory for more options. **S-Special** - provide more details.

* NO/NC means output condition at NO LIQUID/Tank is empty

** Alarm levels measured from bottom of the bottle, example: 55N means 55mm NO

IDEA DESIGN PROTOTYPING TESTING MANUFACTURING

OEMSYS *smart system solutions*
OEMSYS Sp. z o.o.
 Fabryczna 1
 34-600 Limanowa
 Poland

DTS/0019 Rev.1